



# DH PICOITX 02

User Manual

DH electronics GmbH | Am Anger 8 | 83346 Bergen | Germany

THE ART OF INNOVATION

## History

Version	Date	Description or changes	Name
1.0	2013-05-14	DH picoITX operating instructions	AG
1.1	2013-05-28	English language translation	AG
1.2	2013-11-20	Add RS485 Notes at 2.5 Industrial connector	AG
1.3	2014-01-21	Add Notes to table 1 Add input, output voltages to table 6 Add GND_OC note to X8 chapter	AG
1.4	2014-03-21	GPIO_A and GPIO_H exchanged in table 1	AG
R01	2016-12-06	Added information about redesign from DH picoITX to DH picoITX R02	SG
R02	2016-12-13	Added information after review	SG
R03	2016-12-15	Added information after review	SG
R04	2016-12-20	Changes to block diagram	AG

**Table of contents**

1	Introduction .....	4
1.1	Main features.....	4
1.2	Block diagram.....	5
2	Interfaces .....	6
2.1	SODIMM-200 connector (X1).....	6
2.2	B2B box connector (X2) .....	6
2.3	Ethernet (X4).....	8
2.4	Full-function UART (X5).....	9
2.5	Industrial connector (X8) .....	9
2.6	USB (X10).....	11
3	LEDs.....	12
4	Voltage supply (X6 or X7) .....	13
4.1	Battery.....	13
5	Mechanical system .....	15
5.1	Dimensions.....	15
5.2	DHCOM cooling solution.....	16
5.3	Adapter board mounting examples.....	16
6	Electrical and thermal parameters.....	17

# 1 Introduction

The picoITX module is a general purpose base board for computer modules compliant with the DHC0M standard. In addition to being cost-optimised, it also offers common standard interfaces as well as serial and digital inputs and outputs. A flexible extension interface also allows a touch-screen and a separate expansion board to be connected. This modular system offers a wide range of applications for the user.

By selecting the appropriate DHC0M standard module, the required system performance is scalable. The customary board support packages for Linux, Android and WinCE are available. The user can fully concentrate on developing applications. Here too, DH electronics is able to support customers with its extensive know-how and user-friendly development environments for DHC0M platforms.

As a one-stop provider, DH electronics would also be pleased to supply, upon request, a customised, ready-to-ship solution. You, the customer, can have a fast, reliable and cost-effective system solution from a single source when you decide for the DH picoITX modular system.

## 1.1 Main features

- DHC0M standard compliant
- BSPs for Linux, Android and Windows CE
- 1x Ethernet 10/100Mbit
- 1x USB Host 2.0 (optional 2 x USB Host 2.0)
- 1x USB OTG 2.0
- 1x RS232 (Rx / Tx / Rts / Cts) / alternatively RS485 is possible
- 1x RS232 (Rx / Tx / Rts / Cts)
- 1x UART (Tx / Rx)
- 1x CAN up to 1 MBaud (alternative CAN Rx / Tx)
- 1x I2C
- 1x SPI
- 24bit RGB Display Interface
- 4-wire resistive touch-screen
- 1x PWM
- 4x IOs
- 4x GPIOs
- 1x Interrupt highest priority
- 1x Optocoupler (second Input alternative to CAN)
- 1x Open collector (second Output alternative to CAN)
- 1x "Run" LED

- 1x "Status" LED
- 1x Battery connection for date and time back-up

## 1.2 Block diagram

Figure 1 shows an overview of the DH picolTX board.

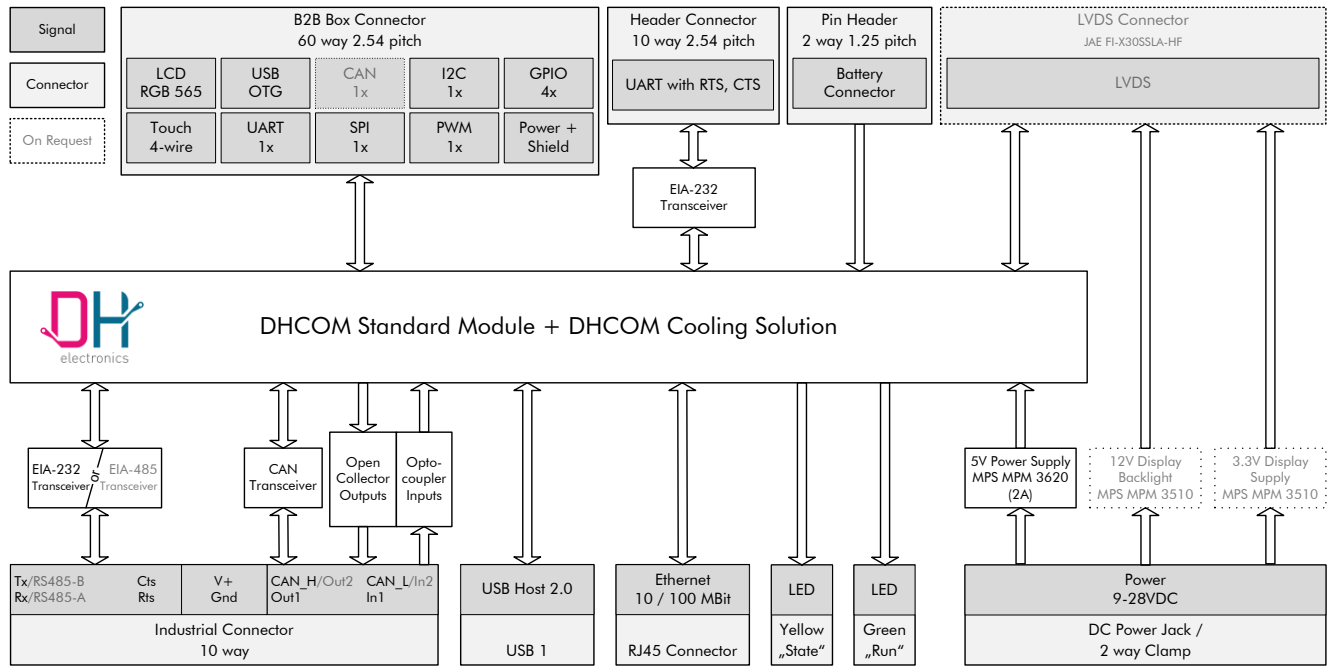

Figure 1: DH picolTX block diagram

## 2 Interfaces

The following subsections describe all of the interfaces of the DHPico board. Figure 2 serves as an overview for the subsections that follow.

The drilled and plated holes are connected to GND\_EARTH.

Per default GND\_EARTH and GND\_IN are connected.

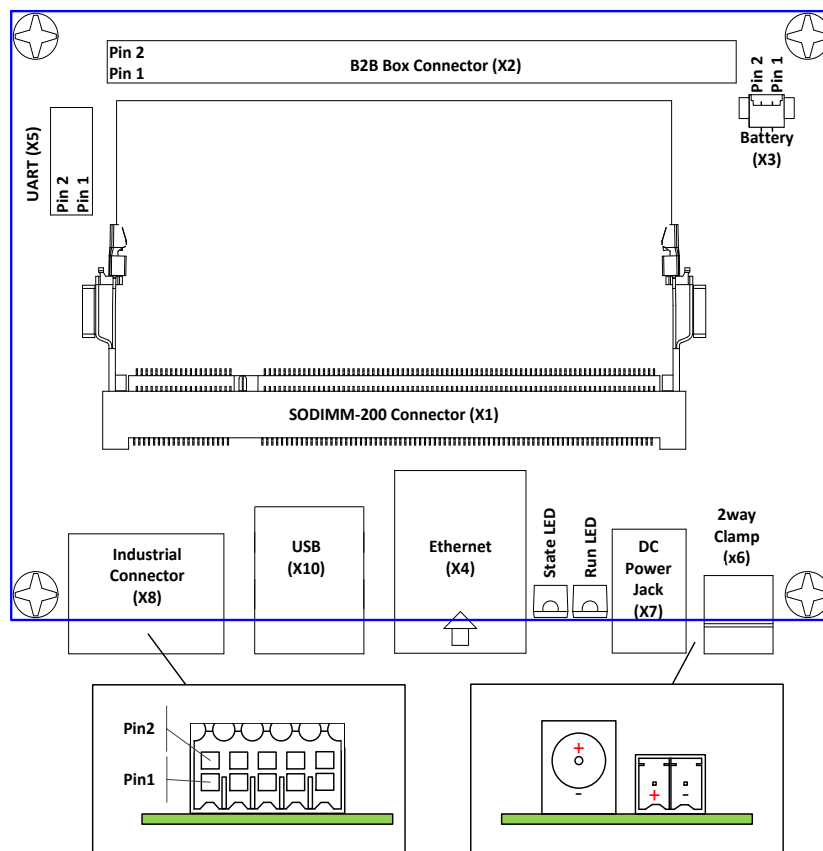

Figure 2: Overview of the interfaces

### 2.1 SODIMM-200 connector (X1)

Any DHC0M standard module can be plugged into the SODIMM-200 connector.

### 2.2 B2B box connector (X2)

The RM 2.54 board-to-board connector provides a simple way of connecting an adapter board. Touch-screen adaption, for example, may be performed on the adapter board. All possibilities are open, especially for applica-

tions with a touch-screen. An on-board resistive touch interface can be used or a capacitive touch-screen can be realized without any difficulty via interfaces such as USB, I2C, UART or SPI.

In addition, the extension connector offers industrial interfaces such as CAN, which can be handled on an expansion board without any difficulty.

The arrangement of the signals on the connector also allows connecting two expansion boards (see Figure 12 on page 16). For example, these could be one board above the DH picolTX Board for a display and another below it for a CAN interface.

Pin assignments:

Pin	Name	Description	Pin	Name	Description
1	VCC_IN <sup>2)</sup>	Filtered supply voltage	2	GND_IN <sup>3)</sup>	Ground
3	+5V <sup>1)</sup>	5VDC voltage	4	GND_IN <sup>3)</sup>	Ground
5	TSPX	Resistive touch-screen: 4 wire (X +)	6	TSMX	Resistive touch-screen: 4 wire (X -)
7	TSMY	Resistive touch-screen: 4 wire (Y -)	8	TSPY	Resistive touch-screen: 4 wire (Y +)
9	LCD_R2*	LCD display data red 2	10	LCD_R3*	LCD display data red 3
11	LCD_R4*	LCD display data red 4	12	LCD_R5*	LCD display data red 5
13	LCD_R6*	LCD display data red 6	14	LCD_R7*	LCD display data red 7
15	LCD_G2*	LCD display data green 2	16	LCD_G3*	LCD display data green 3
17	LCD_G4*	LCD display data green 4	18	LCD_G5*	LCD display data green 5
19	LCD_G6*	LCD display data green 6	20	LCD_G7*	LCD display data green 7
21	LCD_B2*	LCD display data blue 2	22	LCD_B3*	LCD display data blue 3
23	LCD_B4*	LCD display data blue 4	24	LCD_B5*	LCD display data blue 5
25	LCD_R0*	LCD display data red 0	26	LCD_R1*	LCD display data red 1
27	LCD_G0*	LCD display data green 0	28	LCD_G1*	LCD display data green 1
29	LCD_B0*	LCD display data blue 0	30	LCD_B1*	LCD display data blue 1
31	LCD_B7*	LCD display data blue 7	32	LCD_B6*	LCD display data blue 6
33	LCD_VSYNC*	LCD frame or vertical sync. puls	34	LCD_EN*	LCD display enable
35	LCD_HSYNC*	LCD line or horizontal sync. puls	36	GPIO_PWM*	PWM (or LCD_contrast)
37	LCD_PCLK*	LCD pixel clock	38	GPIO_G*	General Purpose I/O
39	GPIO_B*	General Purpose I/O	40	GPIO_H*	General Purpose I/O
41	I2C1_CLK*	I <sup>2</sup> C clock line	42	I2C1_DAT*	I <sup>2</sup> C data line
43	USB_OTG_VBUS	OTG Client: VBUS Input line OTG Host: USB bus supply voltage	44	USB_OTG_D+	USB OTG differential Signal positive line
45	USB_OTG_ID*	OTG ID Pin	46	USB_OTG_D-	USB OTG differential Signal negative line
47	SPI1_CS0*	Slave select signal	48	SPI1_MISO*	SSP receive data line
49	SPI1_CLK*	SPI clock line	50	SPI1_MOSI*	SSP transmit data line
51	INT_HIGHEST_PRIO*	Highest priority interrupt pin	52	GPIO_A*	General Purpose I/O
53	CAN_TX*	CAN transmit data line (alternative to CAN at X8)	54	CAN_RX*	CAN receive data line (alternative to CAN at X8)
55	UART3_RX*	Serial port receive data line	56	UART3_TX*	Serial port transmit data line
57	+5V <sup>1)</sup>	5VDC voltage	58	GND_IN <sup>3)</sup>	Ground
59	VCC_IN <sup>2)</sup>	Filtered supply voltage	60	GND_IN <sup>3)</sup>	Ground

Table 1: B2B connector assignments

#### Notes:

- <sup>1)</sup> +5V is generated from VCC\_IN and is the supply voltage for DHpico Board and DHCOM core module. As described in chapter 4 the max. rating of the 5V voltage supply is 7.5W. Therefore, when using the 5V supply on the B2B connector, attention must be paid to how much current is consumed on the DH picoITX board.
- <sup>2)</sup> VCC\_IN is the filtered power supply voltage which is connected to X6 or X7. See Figure 3.
- <sup>3)</sup> GND\_IN is the filtered ground which is connected to X6 or X7. See Figure 3.

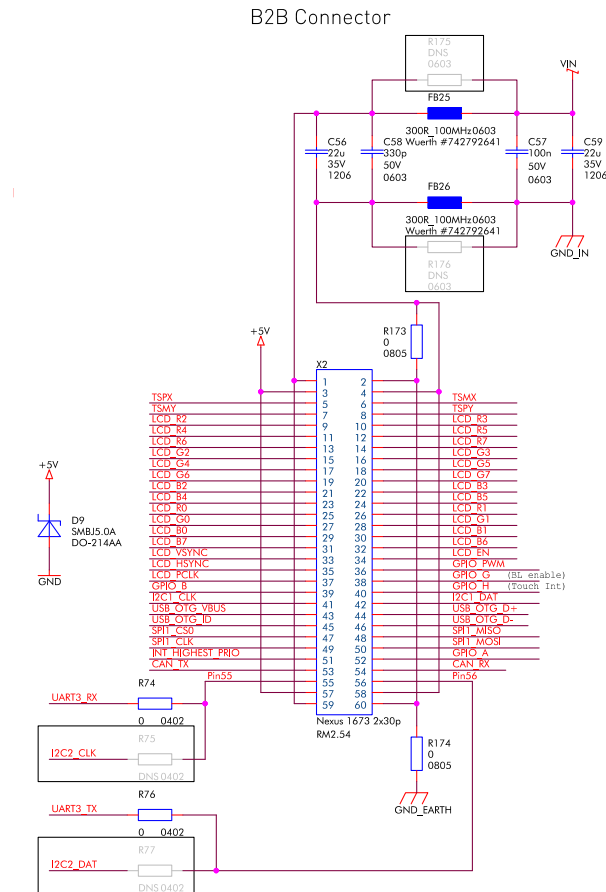

Figure 3: Filtering VCC\_IN

- All \* marked signals are only 3,3V tolerant.

## 2.3 Ethernet (X4)

On the front of the DH picoITX board the connector X4 offers an RJ45 interface at 10/100Mbps. The connector is equipped with link and speed LEDs.



## 2.4 Full-function UART (X5)

Full function UART 1 of the DHCOM module is connected to the RM 2.54 header socket X5. An RS232 transceiver is integrated on the DH picolTX board between the DHCOM module and the connector. The 10-way header socket is assigned as follows:

Pin	Name	Description	Pin	Name	Description
1	NC	Not connected	2	NC	Not connected
3	RX	Receive data line	4	RTS	Request to send
5	TX	Transmit data line	6	CTS	Clear to send
7	NC	Not connected	8	NC	Not connected
9	GND	Ground	10	-	

Table 2: Full-function UART pin assignments

**Note:** The bootloader of the DHCOM module can be accessed via the DHCOM UART 1. The Linux console in the standard image can also be operated via this COM port.

## 2.5 Industrial connector (X8)

The DHCOM UART 2 is connected to the 10-way industrial connector. An RS232 transceiver is integrated on the DH picolTX board between the DHCOM module and the connector. The DH picolTX board may also optionally be ordered with an RS485 transceiver at this place.

In addition, this connector offers a non-insulated CAN-Interface with up to 1Mbaud using a TJA1040T transceiver, one optocoupler input and one open collector outputs. Alternative to the CAN-Interface it is possible, to use a second input and a second output instead of the CAN-Interface.

The optocoupler input can be switched with 12–24VDC, whereby at this point it must be ensured that the input has it’s own ground (GND\_OC). GND\_OC has no connection to DH picolTX circuit GND or GND\_IN.

The drawing below shows the schematic of the input:

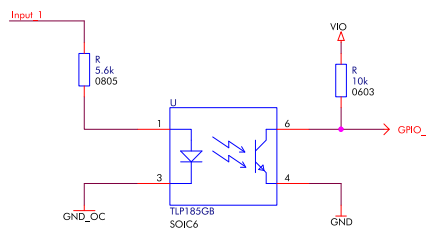

Figure 4: Optocoupler Input

As shown in Figure 4 the state of Input1 can be queried via DHCOM GPIO\_E (optional Input2 can be queried via DHCOM GPIO\_C).

The output is connected as open collector and can drive a maximum current of 100mA at a maximum switching voltage of 24V +10%. The drawing below shows the schematic of the output:

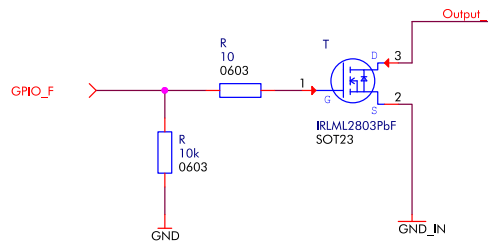

Figure 5: Open Collector Output

As shown in Figure 5 the state of Output1 can be switched via DHCOM GPIO\_F (optional Output2 can be switched via DHCOM GPIO\_D).

The table below shows the pin assignments of the industrial connector X8:

Pin	Name	Description	Pin	Name	Description
1	RXD or RS485_A	Receive data line / RS485 data A	2	TXD or RS485_B	Transmit data line/ RS485 data B
3	RTS	Request to send	4	CTS	Clear to send
5	GND_IN	Ground DH picoITX supply voltage	6	GND_OC	Ground for optocoupler inputs
7	Output_1	Open Collector Output 1	8	CAN_H or Output_2	CAN_High / Open Collector Output 2
9	Input_1	Optocoupler Input 1	10	CAN_L or Input_2	CAN_LOW / Optocoupler Input 2

Table 3: Industrial connector pin assignments

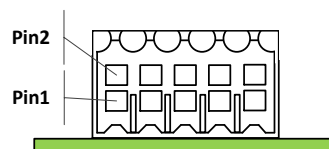

Figure 6: Industrial connector X8

**Note:** Since the inputs and outputs do not have any protective circuitry, they should only be operated in their specified operating state.

The type of connector used is the Weidmüller 1728010000. The following plugs can be used as the mating piece:

- **Weidmüller Art. No. 1727660000 (black)**

- **Weidmüller Art. No. 1727580000 (orange)**

#### **Note to CAN interface:**

If DHpico provides the CAN interface on the industrial connector, the CAN Rx / CAN Tx signals of X2 are not available.

#### **Note to RS485 Transceiver:**

If DHpico provides RS485 on the industrial connector, the control lines RTC and CTS are not connected. In the list below you will find the receiver and transmitter control pins of the RS485 transceiver:

Name	DHCOM GPIO	AM35xx pin number	AM335x pin number	i.MX25x pin number	i.MX6 pin number
Transmit enable (active high)	DHCOM GPIO_M	97	55	9	192
Receive enable (active low)	DHCOM GPIO_N	98	54	117	193

## **2.6 USB (X10)**

By default one USB 2.0 host port on the front of the DH picolTX board can be used for low-, full- and high-speed operation.

Optional a second USB 2.0 host port on the bottom side of the DH picolTX board can be available.

Whether both USB ports are supported and can be used with which transmission speed depends on the DHCOM core modules used in each case. A detailed description can be found in the respective DHCOM core module User Manual.

### 3 LEDs

The DH picolTX board is equipped with two LEDs. One is for the "Status" (yellow) and the other is for "Run" (green).

The green "Run" LED is connected to the RESET\_OUT of the DHCOM module, and so it indicates that the DHCOM core module is no longer in reset state.

The yellow "Status" LED is connected to the DHCOM GPIO\_I and can be used by the customer in any way whatever. For example, it could indicate that the operating system or a customer application was started successfully.

In addition, it can be used as an update status indicator in the case of a headless device. The DHCOM bootloader enables the use of an update status LED (see the bootloader update description for details).

## 4 Voltage supply (X6 or X7)

The voltage supply for the DH picolTX board is 9–28 VDC. An on-board regulator generates a supply voltage of 5V (max. 2A). This voltage powers the DHCOM core module and peripherals on the DH picolTX board. The 5V is also connected to the B2B box connector (X2). If the 5V are also used on an adapter board, a power calculation must be performed to ensure that the maximum of 7.5W is not exceeded. The power consumed by the DH picolTX board largely depends on the core module used and the peripherals connected to the USB ports.

The DH picolTX supply voltage is connected either to the 2-way connector X6 or to the connector X7. The pin assignments of both connectors are shown in the following figures:

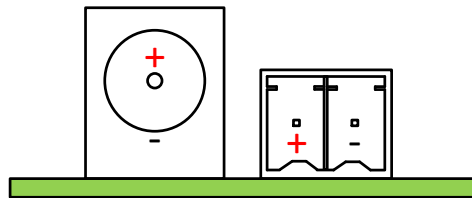

Figure 7: Pin assignments of connectors X6 and X7

The following Phoenix plugs may be used as connectors for the voltage supply connector X6:

- Art. No.: 1840366 (MC 1,5/ 2-ST-3,5)
- Art. No.: 1863152 (MCVR 1,5/ 2-ST-3,5)

### 4.1 Battery

A battery for backing up the time and date information can be connected to connector X3. One example of a suitable battery is the Varta CR2032 S WC with order number 6032101031.



Figure 8: Varta battery

This can be obtained from Multi-Bauelemente-Service GmbH (<http://www.mbs.to/>), for example.

Battery details:

Description	Value
Type	Li-Manganese dioxide / Organic Electrolyte
Nominal Voltage	3V
Typical Capacity	230mAh
Discharge Temperature	-20°C – 70°C

**Table 4: Battery properties**

The connector on the circuit board is a Molex (Art. No.: 53261-0271) 1.25mm PicoBlade connector. The Molex 51021-0200 can be used as the mating connector.

The pin assignments of the connector X3 are shown in the table below:

Pin	Name	Description	Pin	Name	Description
1	V_BAT	Battery voltage	2	GND	Ground

**Table 5: Battery connector**

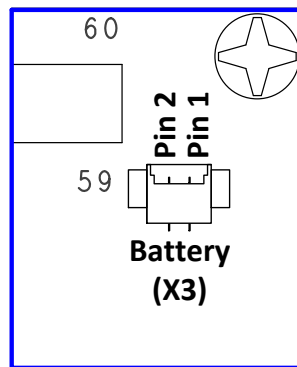

**Figure 9: Pin assignments of connector X3**

## 5 Mechanical system

### 5.1 Dimensions

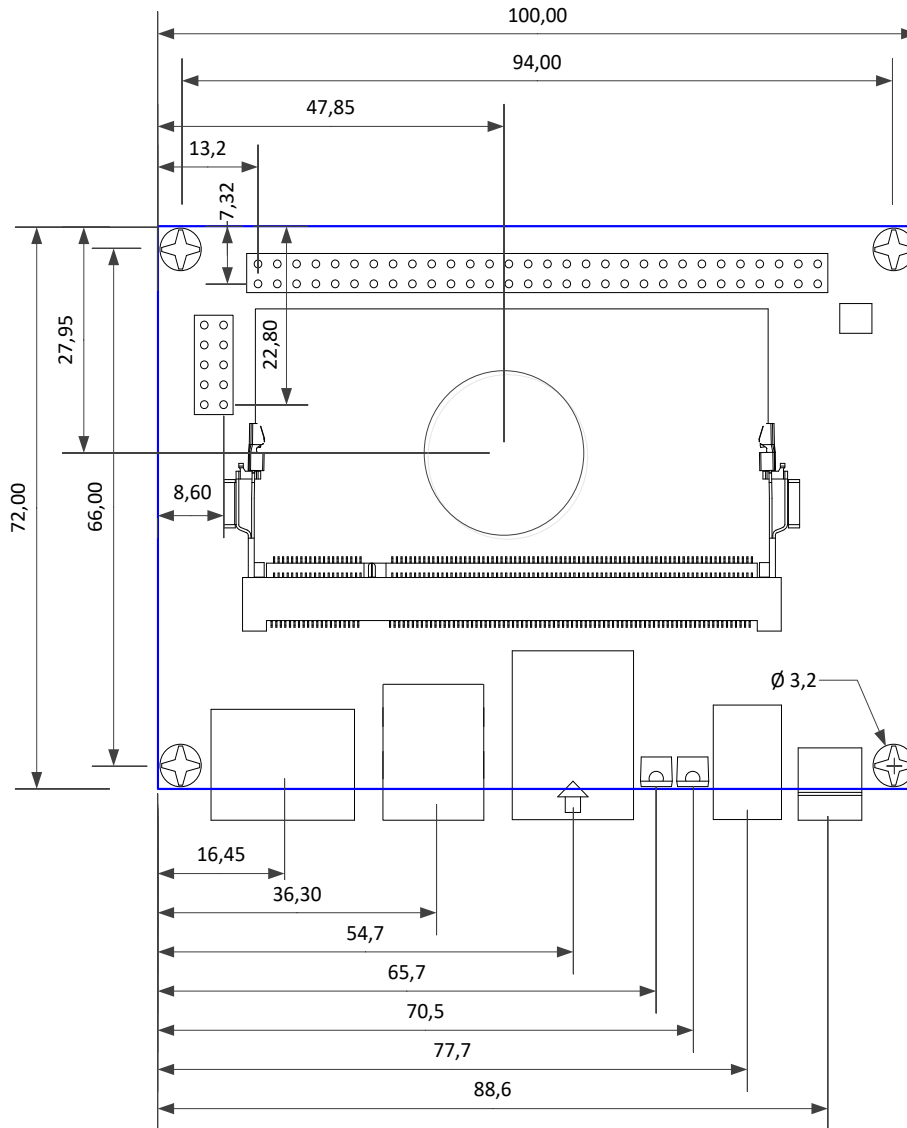

Note: All dimensions are in millimeters.

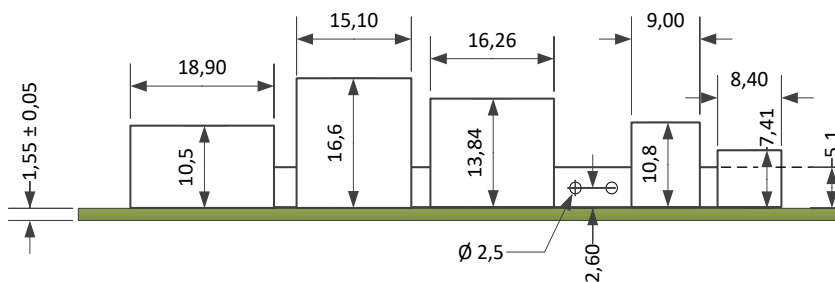

Figure 10: Mechanical dimensions

### 5.2 DHC0M cooling solution

The DH picoITX uses the DHC0M cooling solution to transfer the heat from the cpu to the mainboard. For more information about the DHC0M cooling solution have a look at the DHC0M design guide.

### 5.3 Adapter board mounting examples

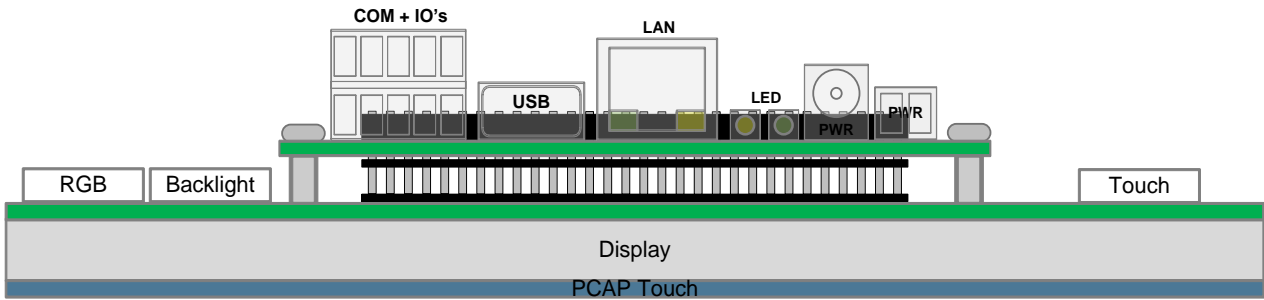

Figure 11: Display adapter mounting example

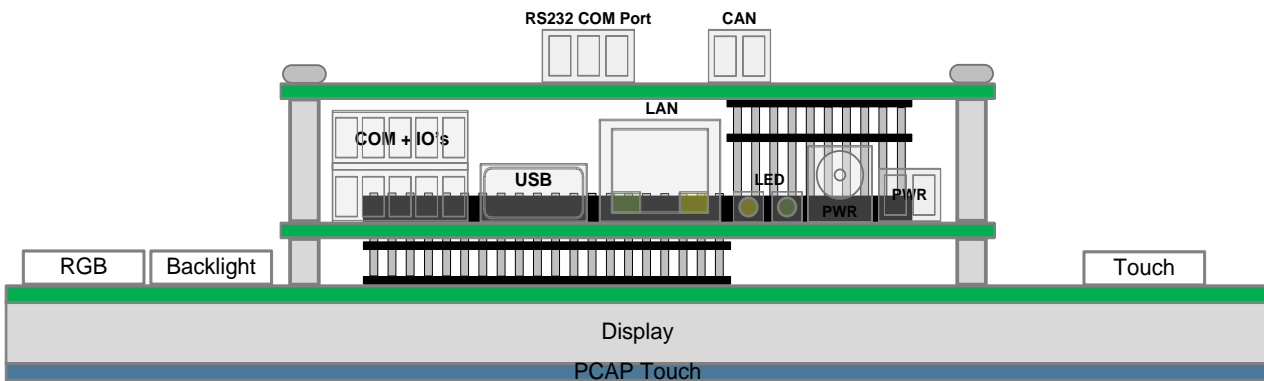

Figure 12: Mounting example with two adapter boards



## 6 Electrical and thermal parameters

Description	Min	Type	Max	Unit
Voltage supply DH picoITX (X6 or X7)	9		28	VDC
On Board 5V voltage supply			2.0	A
Optocoupler input voltage range (see X8)	12		24	V
Open collector output current (see X8)			100	mA
Open collector switching voltage (see X8)		24	26.4	V
Digital input high voltage (belongs to X2)	2.0	3.3		V
Digital input low voltage (belongs to X2)		0	0.8	V
Digital output high voltage (belongs to X2)		3.3		V
Digital output low voltage (belongs to X2)		3.3		V

Table 6: Electrical parameters

Description	Min	Type	Max	Unit
Ambient temperature range	-40		85	°C

Table 7: Temperature range